

As manufacturer of safety equipment, the Cobianchi Lifteile AG company is responsible for the design and manufacture of the Cobianchi PC30DA/PC60DA progressive safety gears.
 In order to make the production, the distribution, and the maintenance of our progressive safety gears and brake devices easier for the manufacturers of the framework and for the installation companies, these operating instructions have been established.

These operating instructions document the standard versions PC30DA for installation width 180/240mm and PC60DA with installation width 240mm. If your installation type differs from the versions described in these instructions, please contact your technical office or the responsible construction department.

In the following you will find important notes, which if properly observed will contribute to an impeccable installation and operation.

The following three drawings have to be enclosed with these instructions:

Drawing no.	Brake type	Front view, top view, side view
30DA-BA01-2	PC30DA installation width 180/200mm	Assembly drawing FV with Pos. no.
30DA-BA01-6	PC30DA installation width 240mm	Assembly drawing FV with Pos. no.
60DA-BA01-2	PC60DA installation width 240mm	Assembly drawing FV with Pos. no.

These operating instructions consist of some pages of text (number depending on the language) and three drawings. Customer-specific solutions may require deviating installation sequences. The progressive safety gears and the brake devices can be installed at the top of or underneath the cabin, considering the position of the connection shaft and the lifter rope engagement. For detailed information, please refer to our technical documentation.

Subject to deviations from the standard versions described here.

To be observed prior to the installation:

The two types PC30DA and PC60DA are equipped as progressive safety gear downwards in combination with brake devices upwards. One pair (basic unit) consists of two adjusted and sealed green safety gear heads (Pos. 1). They can be ordered with top lifter rope engagement or bottom lifter rope engagement. It has to be checked that the descriptions "up" and "down" on the wedge guide plates (Pos. 11) correspond to the facts. Note: The safety gear heads (Pos. 1) must not be installed rotated by 180 degrees, upside down. All performance specifications on the type plates refer to the use in pairs. The serial numbers are embossed on the safety gear heads (Pos. 1). These numbers must correspond to the serial number on the type plates attached and enclosed and must be able to be allocated to the serial number of the installation. If this is not the case, then a mistake has been made and it is necessary to refer back to the purchasing department, your own stores department or directly with the manufacturer.

1. Assembly

1.1. Assembly and alignment of safety gear heads

As a standard, delivery is made as basic unit (two green safety gear heads, Pos. 1), fully mounted with sealed adjustment. The following accessories are available on request: four gusset plates (Pos. 3), two support plates (Pos. 6), one lifter on the left and right (Pos. 2), stop-trigger bushing (Pos. 8) and one limit switch (Pos. 7). The trigger bushing (Pos. 8) and the limit switch (Pos. 7) are mounted on the safety gear rope side. The installation of the safety gear heads (Pos. 1) in the safety gear frame in any case has to be made using four bearing shafts (Pos. 13). The bearing shafts (Pos. 13) and the mounting holes in the housings should be greased.

If gusset plates (Pos. 3) are provided, they must be screwed to the frame using an adequate number of M12 or M16 screws. Secure absorption of the torque acting on the frame structure via the gusset plates (Pos. 3) during the brake process must be ensured.

The green safety gear heads (Pos. 1) are secured in a neutral position by means of the pressure springs (Pos. 15) on the side. For each head (Pos. 15) one pressure spring (Pos. 15) is mounted to one bearing shaft (Pos. 13), on the **brake wedge side** (Pos. 10). The M6 set screw (Pos. 14) on the opposite side is used to adjust the position of the safety gear heads (Pos. 1) with respect to the rail. Recommendation: Distance fixed brake shoe (Pos. 12) to guide rail running surface 2.0mm. The running surface width of the brake shoes (Pos. 12) must not be below the minimum value. For correct installation, the distance from the safety gear housing bottom to the rail head front side is normally 3-4mm. This distance should be centred relative to both safety gear housings, using a depth gauge. If necessary, re-adjust cabin guide shoes.

1.2. Mounting of connection shaft between safety gear heads/support plates

The double wedge safety gears described here are designed for an externally positioned connection shaft. The shaft itself is not within our scope of supply. Please use a structural steel tube 20x20x2.5 or 3mm according to DIN2395-3. For the respective length of the connection shaft refer to drawings enclosed. Mounting of the support plates (Pos. 6) has to be made according to the drawings enclosed. Note: The position of the connection shafts must correspond exactly to the indicated position. The shaft is inserted in the two support plates (Pos. 6) with a stop bushing (opposite safety gear rope side) and a triggering bushing (Pos. 8) on the safety gear rope side.

1.3. Mounting of PC30DA torsion springs

For installation width 180mm, the PC30DA safety gear is equipped with **one** double-arm, six-coil torsion spring (Pos. 4) **on the safety gear rope side**. For installation width 240mm **one** double-arm, five-coil torsion spring is provided for the PC30DA safety gear **on the safety gear rope side**. The spring **must** be mounted on the **safety gear rope side** in order to prevent excessive torsion of the connection shaft. Tip for initial assembly: The arms of the torsion spring (Pos. 4) are tensioned (crosswise) during assembly. Do not tighten the bolt in the eye of the torsion spring (Pos. 4) until tensioning has been completed.

1.4. Mounting of PC60DA torsion spring

The PC60DA is equipped **with two** torsion springs (Pos. 4a/b). A double-arm, five-thread torsion spring (Pos. 4a) is installed on the safety gear rope side and a one-arm, six-thread torsion spring (Pos. 4b) is installed **on the opposite side of the safety gear rope**. In the case of the PC60DA, during upwards braking both springs are tensioned, and during downwards braking only the torsion spring on the safety gear rope side (Pos. 4). Tips for initial assembly: The arms of the torsion springs (Pos. 4a/b) are tensioned (crosswise) during assembly. Do not tighten the bolts in the eye of the torsion spring (Pos. 4a/b) until tensioning has been completed.

1.5. Mounting of lifter

The lifters (Pos. 2) are connected to the brake wedges (Pos. 10) by means of the eyebolt (Pos. 16). Please observe the correct order: 1. Put lifter (Pos. 2) with elongated hole over eyebolt (Pos. 16), 2. Slide washer over eyebolt (Pos. 16), 3. Slide pressure spring over eyebolt (Pos. 16) up to washer and slightly press spring together 4. Loosen locking nut until eyebolt (Pos. 16) protrudes from nut by approx. one turn. Then insert connection shaft through support plates (Pos. 6) and lifter (Pos. 2) and position in the support plates by means of the stop and triggering bushing (Pos. 8). To make it easier to insert the connection shaft in the lifter (Pos. 2) slightly lift brake wedges (Pos. 10) Then check that all bolts, nuts, and headless screws of the torsion spring (Pos. 4) are tightened and that **the brake wedges (Pos. 10) of both safety gear heads (Pos. 1) synchronously stop at the guide rail when the speed limiter is activated and have the same vertical position when in open position/neutral position. In the case of great centre distances the connection shaft has to be reinforced.**

1.6. Mounting for safety-limit switch

Screw limit switch (Pos. 7) to the support plate (Pos. 6) on the safety gear rope side and check that the triggering bushing (Pos. 8) securely activates the limit switch (Pos. 7) in both directions up/down through the rotation of the connection shaft.

1.7. Type plate

Before attaching the enclosed type plate in a clearly visible position of the frame, the intended surface must be cleaned and be completely dry. The adhesive surface of the type plate must not be touched over a large surface. After adhering press firmly.

1.8. Indicating label for oiled rails

Every progressive safety gear or brake device for use with oiled rails is supplied with a yellow indicating label. This should be attached in a clearly visible position (e.g. on rail oiler). Only an ordinary machine oil of the viscosity class ISO VG 68-150 must be used without any extreme-pressure additives (lubrication oil C according to DIN 51517, part 1). Because lubricating oils for gearboxes, engines or hydraulic units frequently contain additives, they are not suitable for this application.

2. Connection

Wire limit switch (230V, 4A) (Pos. 7) and check function.

Connect safety gear rope with rope end connections of safety rope connector (Pos. 9) at lifter (Pos. 2). The release force at the lifter (Pos. 2) required for the safety gear to engage is maximally 150-250N. It must be ensured that the tensile force in the limiter rope generated by the released speed limiter is at least 2 times the force required for the safety gear to engage (however, at least 300N)

3. Commissioning

Note: To be observed prior to the first safety gear test:

In all cases, dirt, rust-protection, and eventual paint coats have to be removed from the guide rail running surfaces. This is made best using cold cleaning agents or brake disk cleaning agents.

For oiled rails, lubrication oil C according to DIN 51517, part 1 recommended according to yellow label or equal should be used.

4. Maintenance

If the progressive safety gears have been correctly installed, then the maintenance is limited to the following checks:

4.1. Condition of rails:

according to above commissioning instruction

4.2. Triggering linkage:

Synchronous response of draw-in lifters (Pos. 2), connection without any play through connection shaft, free movement of lifters (Pos. 2) and brake wedges (Pos. 10) in the respective direction.

4.3. Limit switch:

Correct electrical/mechanical functioning, actuation ensured

4.4. Safety gear heads:

centred, clean

4.5. Guide-ways of cabin:

In an impeccable condition, not widened.

4.6. Cleanliness:

In general and in particular in the case of building construction elevators and conversions of existing installations: make sure that the safety gear heads (Pos. 1) are protected against contamination with plaster, concrete, cement, mortar, gravel or other materials. Contaminated safety gear heads have to be dismantled and cleaned.

If these simple instructions are followed, then the safety for the users of the elevator as well as for the installation company can be increased significantly.

Ausführung mit Heberangriff unten

Ausführung mit Heberangriff oben

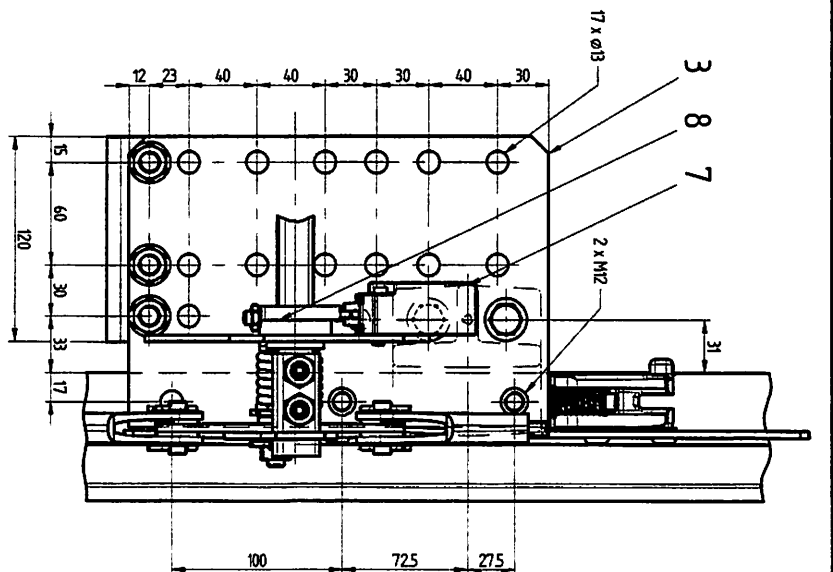
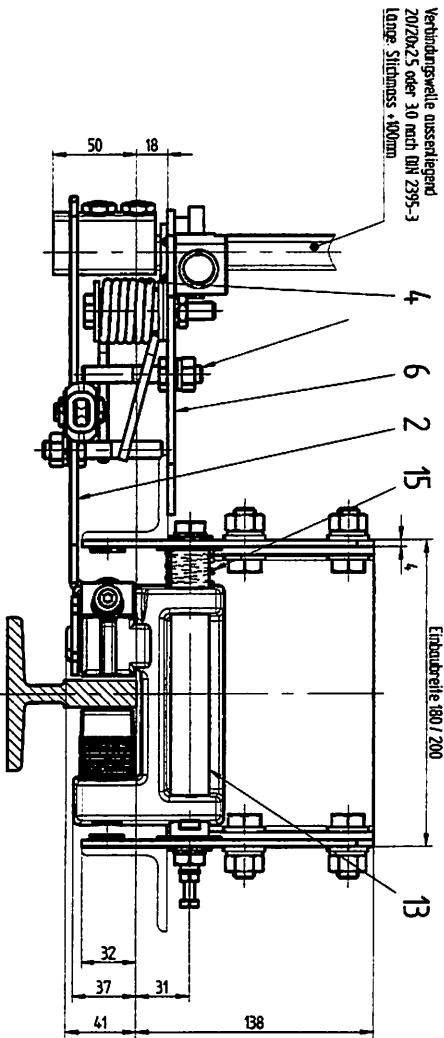
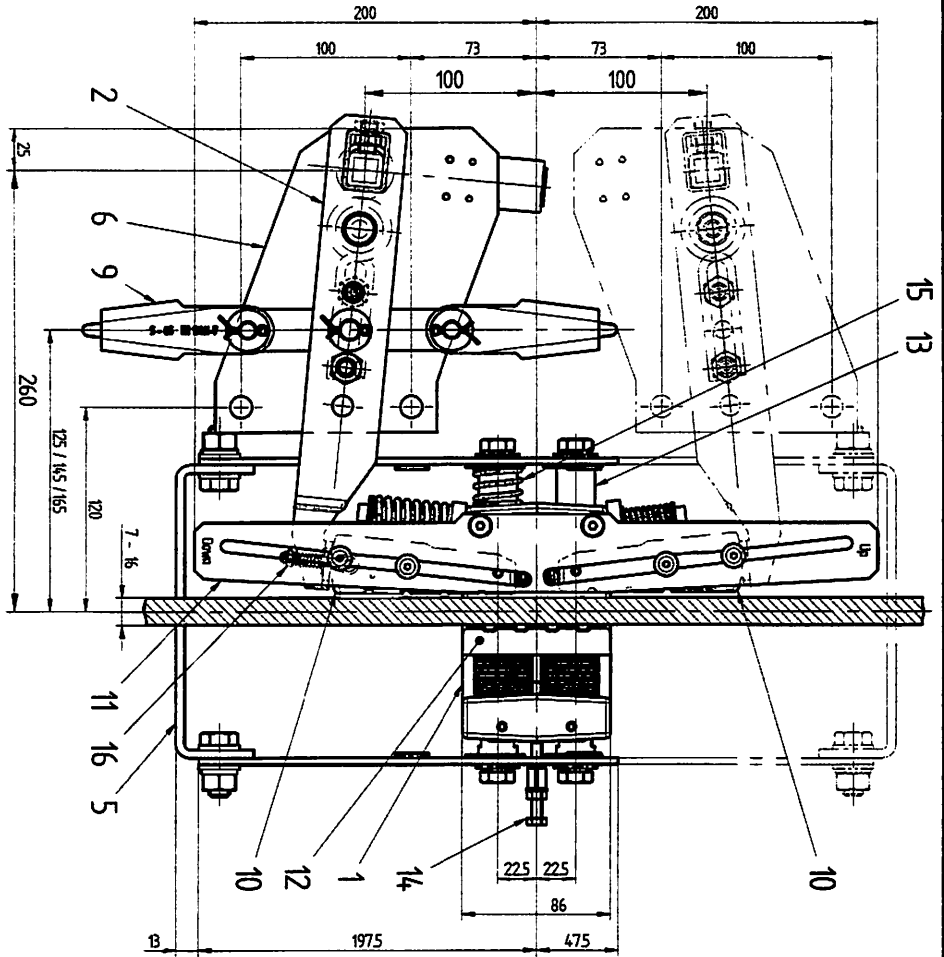

Die Bohrungen in den Knotenblechen dienen zur Befestigung der Fangvorrichtung an Rahmen.
Die Anzahl der Befestigungsschrauben sowie die Festigkeit der Verbindung von Traverse und Hängewinkel müssen durch den Rahmenhersteller anwendungsabhängig und konstruktionsbezogen berechnet werden.

Technische Änderungen vorbehalten

Stückzahlen pro Fangvorrichtung		
2	Kugelschraube	16
2	Druckfeder 180/200mm	15
2	Einstellschraube M6	14
4	Kufeneinbauschraube 180/200mm	13
2	Bremsbacke	12
2	Führungsschleife	11
4	Brennstift	10
1	Selbstschlossganntüte	9
1	Kystrung - Auslösefeder	8
1	Endschalter	7
1	2 Stützblech	6
1	2 Führungsschleife 180/200mm	5
1	1 Rückzugfeder-system Kpl.	4
1	4 Knotenblech	3
1	2 Heber Löhre	2
1	1 Einbaueinheit	1

Zusammenstellung

zu Betriebsvorrichtung
 PL-Typ PC300A mit EB-180/200mm
Geoffelmafi
 COBURG LITFALE AG
 VERKEHRSSERVICE
 Tel. +49 03727025050
 Fax +49 03727025051
 info@geoffelmafi.de
 www.geoffelmafi.de

Material	Zeichnungsnummer	Bezeichnungen
1-3	180809	DH
4	250909	DH
5	250909	DH
6	250909	DH
7	250909	DH
8	250909	DH
9	250909	DH
10	250909	DH
11	250909	DH
12	250909	DH
13	250909	DH
14	250909	DH
15	250909	DH
16	250909	DH

Das Urheberrecht der dieser Zeichnung und allen Bezügen die dem Empfänger vorzulegen ist, bleibt vorbehalten. Nachdruck, Vervielfältigung und Verbreitung, auch auszugsweise, ist ohne schriftliche Genehmigung der Geoffelmafi AG. Nachdruck, Vervielfältigung und Verbreitung, auch auszugsweise, ist ohne schriftliche Genehmigung der Geoffelmafi AG.

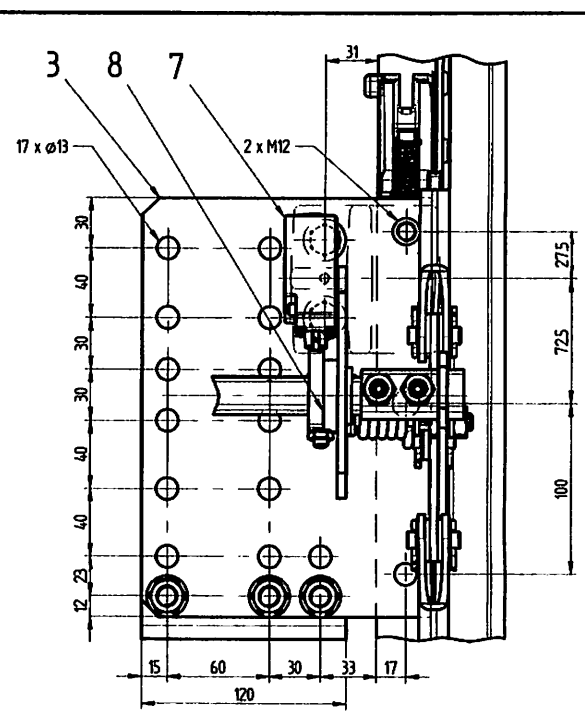
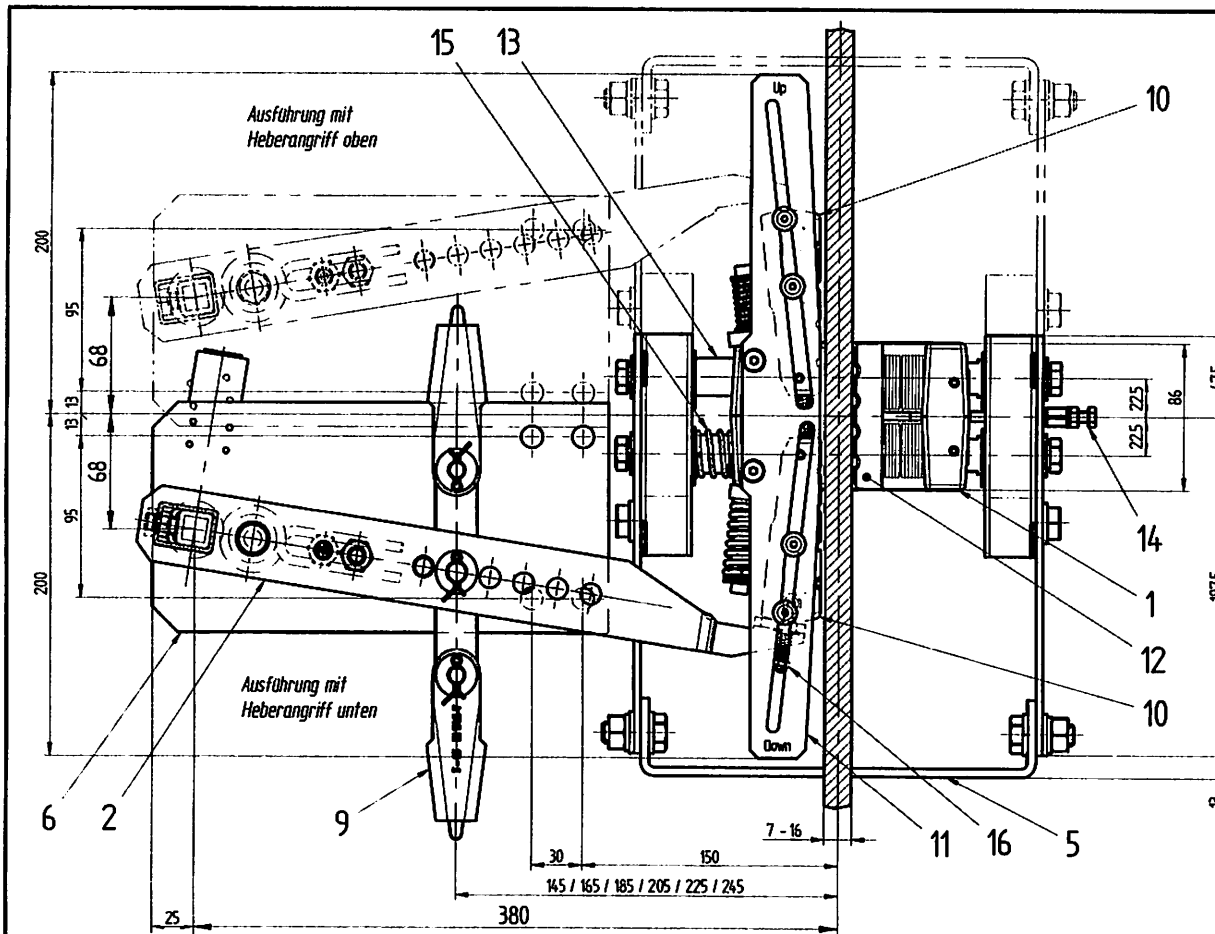

Das Material ist einer Überprüfung an der
 Baueinheit zu unterziehen. Die Baueinheit
 ist nach dem Zusammenbau zu prüfen.
 Die Baueinheit ist nach dem Zusammenbau
 zu prüfen. Die Baueinheit ist nach dem
 Zusammenbau zu prüfen. Die Baueinheit
 ist nach dem Zusammenbau zu prüfen.

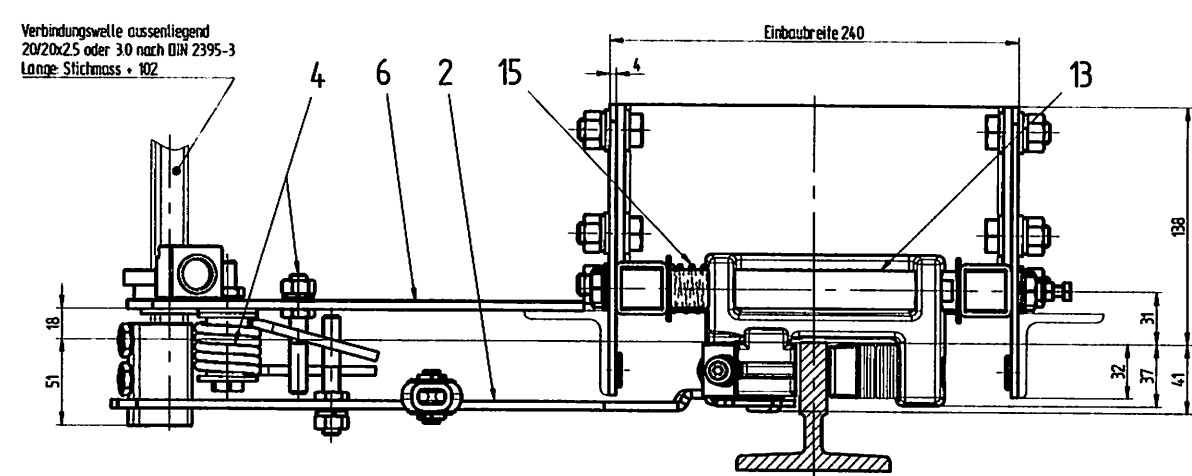

Verbindungswelle aussenlegend
 20/20x25 oder 30 nach DIN 2395-3
 Lange Stichtmass = 102

0-P < 2200kg, ohne Verstärkungsrohre
 0-P > 2200kg, mit Verstärkungsrohre

Technische Änderungen vorbehalten

Stk	Stk	Gegenstand	Pos.	Werkstoff	Modell	Bemerkungen
2	2	Augenschraube	16			
-	2	Druckfeder 180mm	15			
2	-	Druckfeder 240mm	15			
2	2	Einstellschraube	14			
-	4	Aufnahmeachse 240mm	13		1620-36-4	
4	-	Aufnahmeachse 240mm	13		1500-36-4	
2	2	Bremsbarke	12		30DA-16-2	
2	2	Führungsplatte	11		30DA-15-1a/b	
4	4	Bremskeil	10		30DA-12-21-4	
1	1	Seilverschlussgarnitur	9		FV-MZ30-1	
1	1	Anschlag - Auslösehülse	8		DA-MZ28-3	
1	1	Endschalter	7		DA-MZ05-2	
1	1	2 Stützblech	6		60DA-MZ45-3	
1	1	2 Führungssehplatte 240mm	5		30DA-MZ40-3	
1	1	Rückzugfedersystem kpl.	4		60DA-MZ25-3	ø55/5-windig
-	1	1/4 Knotenblech mit Verstärkungsrohr	3		30DA-MZ19-TV	
1	-	1/4 Knotenblech	3		30DA-MZ19-1	
1	1	2 Heber Li-Re	2		60DA-MZ01-1	
-	1	Grundeinheit mit Verstärkungsrohr	1		30DA-N180D16.HV	
1	-	Grundeinheit	1		30DA-N180D16.H	

Änderung	Datum	Stk	Stk	Gegenstand	Pos.	Werkstoff	Modell	Bemerkungen
Zusammenstellung zu Betriebsanleitung FV-Typ: PC30DA mit EB=240mm								
Ausgabe: 25.09.15 / DH							Westfalische H. (H-367) Oberdiesbach Tel. +41 03117205050 Fax +41 03117205051 info@cobianchi.ch www.cobianchi.ch	
वर्गीकरण Cobianchi Liftteile AG							Zeichnungsnummer 30DA-BA01-6	

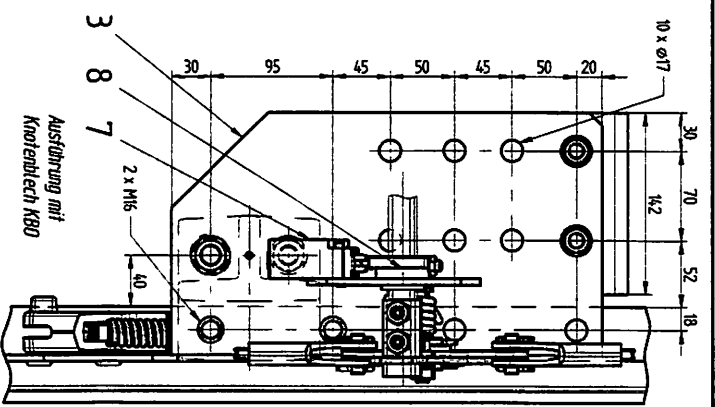
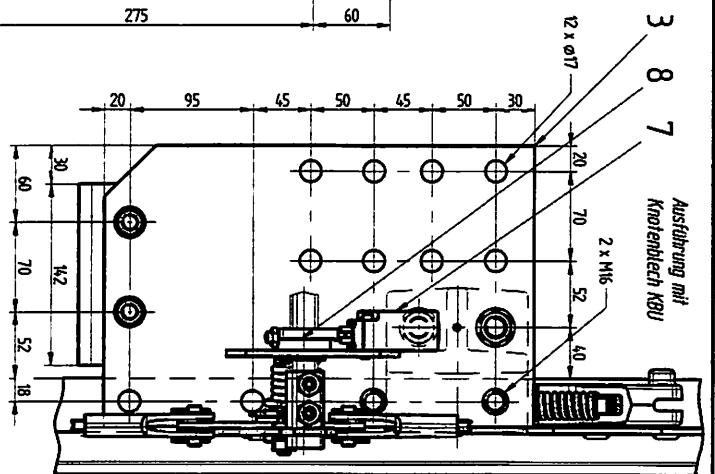
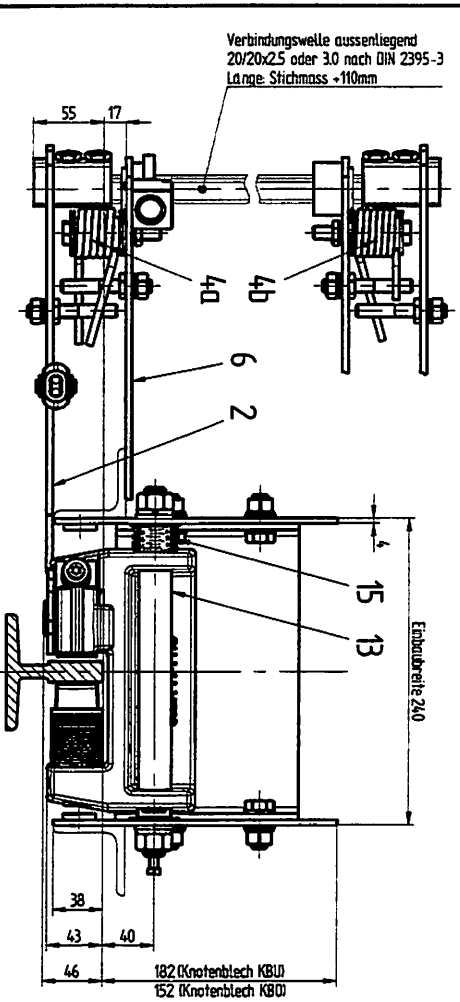
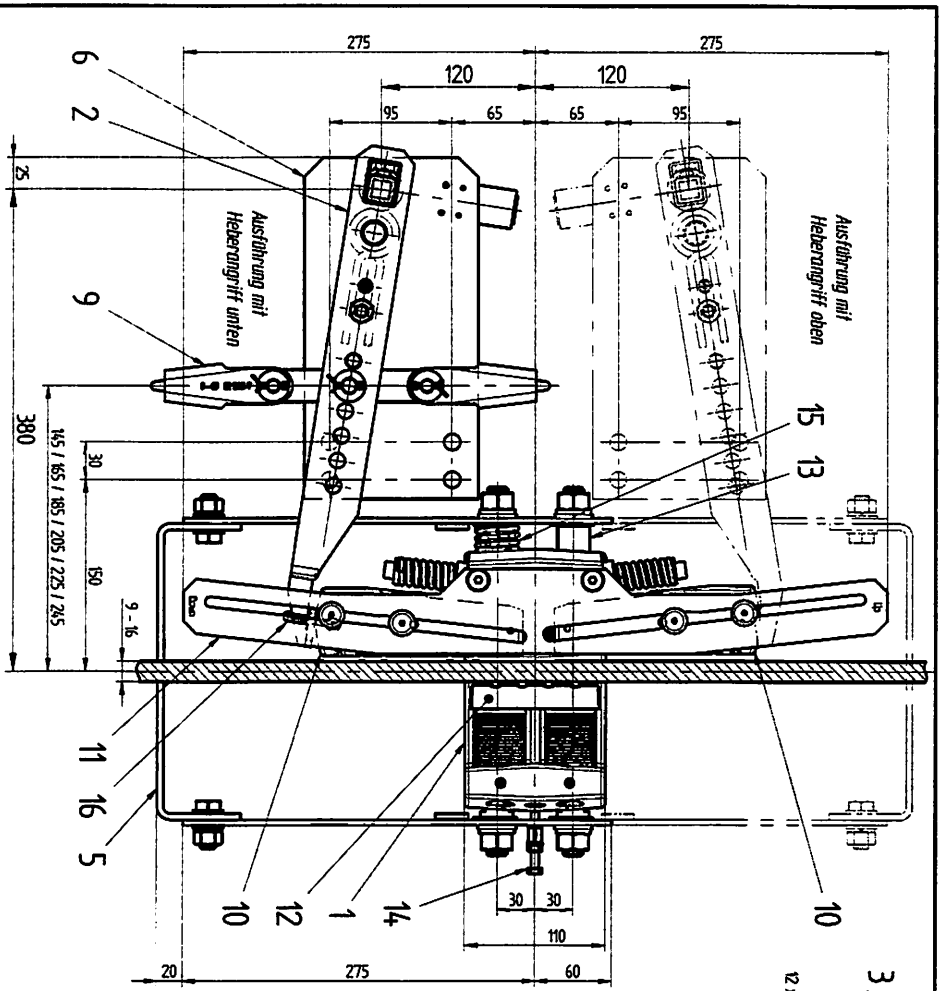

Stückzahlen pro Fangvorrichtung

Stk. / Stk. Lagerbestand	Stk. / Stk. Lagerbestand	Stk. / Stk. Lagerbestand	Stk. / Stk. Lagerbestand
2	2	16	
2	2	15	
2	2	14	
4	4	13	
2	2	12	
2	2	11	
4	4	10	
1	1	9	
1	1	8	
1	1	7	
1	1	6	
1	1	5	
1	1	4a	
1	1	4b	
1	1	3	
1	1	2	
1	1	1	

Hebergriff oben
Hebergriff unten

Technische Änderungen vorbehalten

Die Bohrungen in den Knotenblechen dienen zur Befestigung der Fangvorrichtung im Rahmen. Die Anzahl der Befestigungsschrauben, sowie die Festigkeit der Verbindung von Transverse und Hängewinkel müssen durch den Rahmenhersteller anwendungsabhängig und konstruktionsbezogen berechnet werden.

Das Unternehmen ist für diese Zeichnung und alle Änderungen, die dem Empfänger angeschlossen sind, verantwortlich. Die Verantwortung für die Anwendung der Zeichnung liegt bei dem Empfänger. Die Verantwortung für die Anwendung der Zeichnung liegt bei dem Empfänger. Die Verantwortung für die Anwendung der Zeichnung liegt bei dem Empfänger.

Zusammenstellung

Zu Betriebsanleitung

FV-Typ: PL60DA

Geofor

Werringer Str. 3872 Biersbach
Tel. +49 (0) 3872 9555
Fax +49 (0) 3872 9555
info@geofor.de

Zustimmung:

60DA-BA01-2

Modell	60DA-WZ01b6	Bezeichnungen
Version	1.4	
Gezeichnet	25.08.09	DH
Kontrolliert	26.09.09	DH
Geprüft	26.09.09	HS

EU-Konformitätserklärung für Sicherheitsbauteile
EU-Declaration of conformity for safety components
Déclaration de conformité EU pour les composants de sécurité
Dichiarazione di conformità EU per i componenti di sicurezza

Hersteller / Manufacturer: Fabricant / Produttore:	Cobianchi Lifteile AG Weststrasse 16 CH-3672 Oberdiessbach
Beschreibung / Funktion: Description / Function: Préscription / Fonction: Descrizione / Funzione:	Bremsfangvorrichtung gegen Übergeschwindigkeit abwärts kombiniert mit Bremseinrichtung aufwärts wirkend Progressive safety gear acting in downwards direction with braking device as part of the protection device against overspeed in upwards direction Parachute à prise amortié contre vitesse excessive vers en bas avec dispositif protégeant la cabine qui monte contre une vitesse excessive Paracadute a presa progressivo contro velocità eccessivo verso in basso con dispositivo contro velocità eccessivo verso in alto.
Typ / Type / Type / Tipo:	PC30DA, PC60DA
Seriennummer: Serial number: Numero de série: Numero di fabbricazione:	Siehe Typenschild und Gravur auf Fangkopf see typ plate and engraving on each safety head gardez plaque de fabrication et gravure vedi sulla targhetta e incisione
Baujahr / Year of manufacture: Année de construction / Anno di fabbricazione:	Siehe Typenschild / visible on type plate visible sur plaque de caractéristique / vedi targhetta
Harmonisierte Normen / Harmonized standards: Normes harmonisées / Norme armonizzate :	EN 81-20/50: 2014
Richtlinie / Directive / Directive / Direttiva:	2014 / 33 / EU
Benannte Stelle der Baumusterprüfung: Notified Body carried out EC certificate: Organisme agréé / Organismo autorizzato:	TÜV-SÜD Industrie Service GmbH Westendstrasse 199 D-80686 München
Kennnummer / Identification number: numéro d'identification / numero di identificazione:	0036
Bescheinigung Nr. / EC certificate nr.: No. d'attestation / no. di certificato:	PC30DA: EU-SG 505 PC60DA: EU-SG 506
Q-Systemüberprüfung erfolgt durch: Quality production check / System de qualité vérifié: Organismo per controllo sistema:	TÜV-SÜD Industrie Service GmbH Westendstrasse 199 D-80686 München
Kennnummer / Identification number: Numéro d'identification / Numero di identificazione:	0036
Ausgabedatum / Date of issue / Publié / Rilasciato:	Oberdiessbach, 05.04.2016
Bestätigt / Confirmed / Confirmée / Confermato:	COBIANCHI LIFTEILE AG

Zentralsekretariat
i. A. Katja Schmid

Entwicklung
i. A. Dominik Helfer